



Centrum stavebního inženýrství a.s.
Centre of Building Construction Engineering Plc.
Authorised Body, Notified Body, Certification Body,
Accredited Test Laboratories
workplace Zlín, K Cihelně 304, 764 32 Zlín-Louky



Notified Body 1390

issued

REPORT

about an assessment of the performance of the product

according to REGULATION (EU) No 305/2011 OF THE EUROPEAN PARLIAMENT AND OF THE COUNCIL of 9 March 2011 laying down harmonised conditions for the marketing of construction products and repealing Council Directive 89/106/EEC, Annex V, cl. 1.4 (system 3), as amended

No. 1390-CPD-0060-10/Z(e) rev. 4*

Translation of the Czech version of Report about an assessment of the performance of the product No. 1390 – CPD – 0060 – 10/Z rev. 4 dated 04 January 2016

Application No.: 0060/10/Z
Number of pages: 6

Number of printed copies: 3
Copy No.: 1

The title of the product:
Wooden roof window WDF R8. H, WSA R8. H

according to **EN 14351-1:2006+A1:2010**

which was made by manufacturer:

Roto Okna Dachowe Sp. z o.o.
ul. Lubelska 104, 21-100 Lubartów
Poland

and which was made in factory:

Roto Okna Dachowe Sp. z o.o.
ul. Lubelska 104, 21-100 Lubartów
Poland

Report prepared by : **Ing. Milan Helegda, Ph.D.**

Head of NB 1390 : **Ing. Petr Kučera, CSc.**

Zlín 04.01.2016



1 SPECIFICATIONS OF THE SUBJECT OF TEST

1.1 Specification of specimens: Wooden roof window type WDF R8. H – Specification and sizes of particular specimens are given in the cited test reports

1.2 Description of the product:

Wooden roof window type WDF R8. H, WSA R8. H

Design	Single-light wooden roof window, WDF R8. H, WSA R8. H
Frame	Multilayered pine wood profile (<i>supplier Roto Frank Bauelemente GmbH</i>) Top profile 43 x 66.5, profile no. D07-W329, Side profile 43 x 66.5, profile no. D07-W330, Bottom profile 43 x 66.5, profile no. D07-W328
Casement	Multilayered pine wood profile (<i>supplier Roto Frank Bauelemente GmbH</i>) Top profile 57 x 65, profile no. D07-W339, Side profile 57 x 65, profile no. D07-W340, Bottom profile 62 x 56.4, profile no. D08-W096
Other profiles	<ul style="list-style-type: none"> - The flashings are made by 0.6 mm aluminium (<i>supplier Roto Frank Bauelemente GmbH</i>); - Additional pine wood profile / profile no. 501577 on the top and on the side, cutting with 90° angle and glued on the casement (<i>supplier Roto Frank Bauelemente GmbH</i>); - Aluminium glazing bead / profile no. 495188 on the top and the side, bending corner and covered with a plastic part (<i>supplier Roto Frank Bauelemente GmbH</i>); - Outside the frame is a girder web for the gasket PVC / profile no. 493893, bending in the corner (<i>supplier Roto Frank Bauelemente GmbH</i>); - Outside insulation profile PE, on the side profile no. 552544, on the top profile no. 498703 and on the bottom profile no. 498704, cutting with 90° angle (<i>supplier Roto Frank Bauelemente GmbH</i>)
Decompression and drainage of glazing joint	Open on the full length in the bottom of the glazing
Glazing	Glass Type 2 (10 mm VSG, 16 mm spacer Alu bent in the corner with Argon, 4 mm Float); Glass type 3 (6 mm ESG / 14 mm spacer Alu bent in the corner with Argon / 6 mm ESG); Glass type 4 and 5 (4 mm ESG, 16 mm spacer Alu bent in the corner with Argon, 4 mm Float); Glass type 6E (8 mm VSG, 7 mm spacer Alu bent in the corner with Krypton, 4 ESG, 7 mm spacer Alu bent in the corner with Krypton, 2x3 VSG); Glass type 6S (8 mm VSG, 16 mm spacer Alu bent in the corner with Argon, 2x3 VSG); Glass type 8, 8A and 8G (4 mm ESG, 16 mm spacer Alu bent in the corner with Argon, 6 mm VSG or 4 mm ESG, 14 mm spacer Nirotec EVO or Chromatech Ultra F bent in the corner with Argon, 6 mm VSG); Glass type 9E (4 mm ESG, 10 mm spacer Thermix or Chromatech Ultra F bent in the corner with Krypton, 4 mm ESG, 10 mm spacer Thermix or Chromatech Ultra F bending in the corner with Krypton, 4 mm ESG) or 9A (4 mm ESG, 10 mm spacer Thermix or Chromatech Ultra F bent in the corner with Krypton, 4 mm ESG, 10 mm spacer Thermix or Chromatech Ultra F bending in the corner with Krypton, 4 mm VSG); Glass type 2T (10 mm VSG, 16 mm spacer Nirotec EVO or Chromatech Ultra F bent in the corner with Argon, 4 mm Float); Glass type 3T (6 mm ESG, 14 mm spacer Nirotec EVO or Chromatech Ultra F bent in the corner with Argon, 6 mm ESG); Glass type 4T (4 mm ESG, 16 mm spacer Nirotec EVO or Chromatech Ultra F bent in the corner with Argon, 4 mm Float); Glass type 5T (4 mm ESG, 16 mm spacer Nirotec EVO or Chromatech Ultra F bent in the corner with Argon, 4 mm Float); 9P (4 mm ESG, 10 mm spacer Nirotec EVO or Chromatech Ultra F bent in the corner with Krypton, 4 mm ESG, 10 mm spacer Nirotec EVO or Chromatech Ultra F bent in the corner with Krypton, 4 mm VSG); Glass type 9G (4 mm ESG, 10 mm spacer Nirotec EVO or Chromatech Ultra F bent in the corner with Argon, 4 mm ESG, 10 mm spacer Nirotec EVO or Chromatech Ultra F bent in the corner with Argon, 4 mm VSG) (<i>supplier Roto Frank Bauelemente GmbH</i>)
Gasket	<ul style="list-style-type: none"> - Between frame and casement there are two gaskets: Inside a lip seal TPE / profile no. 457501, corner welded; outside a lip seal TPE / profile no. 325362, corner welded (<i>supplier Roto Frank Bauelemente GmbH</i>); - Between frame and flashing there is a EPDM gasket on the top and the side profile no. D07-W105; on the bottom profile no. D08-W003, corner vulcanized (<i>supplier Roto Frank Bauelemente GmbH</i>);

	- Glazing – outer: EPDM gasket / profile no. 278328, bending in the corner; inside: EPDM gasket / profile no. 358918, cutting with 90° angle (<i>supplier Roto Frank Bauelemente GmbH</i>)
Hardware	2 top hung and horizontal pivot hinges and a handle which can be turned 180° to open and close the window (<i>supplier Roto Frank Bauelemente GmbH</i>)

NOTICE Detailed descriptions of particular specimens are given in the cited test reports.

1.3 The intended use:

Roof window – a construction with a clear or transparent infill determined for installation to an inclined roof structures. It is determined for daily lighting, eventually for natural (direct) ventilation (infiltration) of building inner spaces. It fulfils the function of thermal insulation, acoustic insulation and protection against unfavourable climatic influences. Roof windows are designed to be built into roof slopes of one family houses with habitable loft spaces and other habitable loft spaces designed for permanent dwelling e.g. offices, hotels, schools. The roof windows can be built into roof slopes with pitches between 15° and 90°. Those windows are designed to be installed on battens or rafters. They are integrated with roofing by means of flashings.

Figure 1 – Drawing of wooden roof window, type WDF R8. H

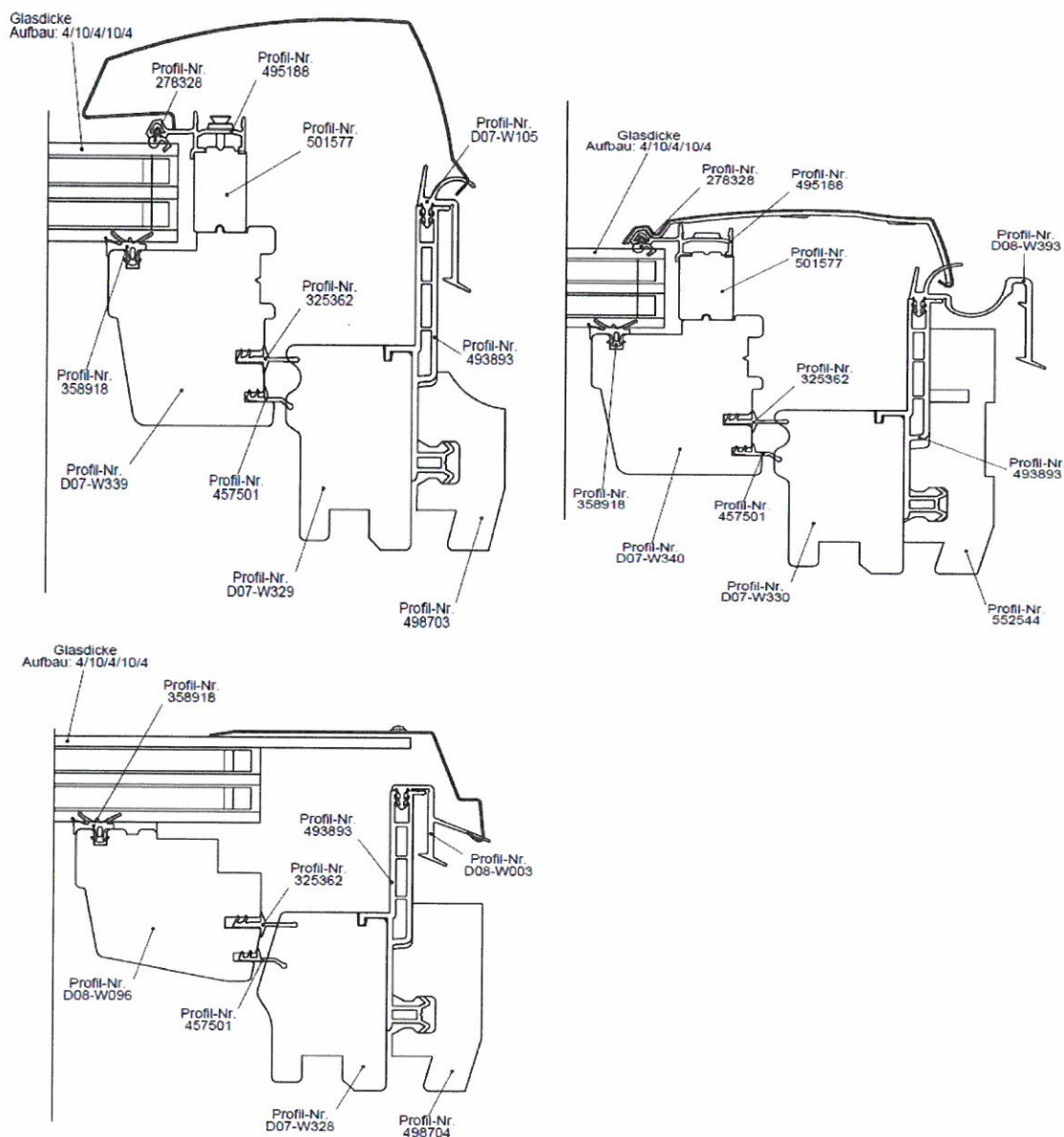

2 SAMPLING

Sampler: Roto Frank Sp. z o.o. (at present Roto Okna Dachowe Sp. z o.o.)

The sample supplier: Roto Frank Sp. z o.o. (at present Roto Okna Dachowe Sp. z o.o.)

Date of the sample supply to laboratory: data given in the cited test reports

Sample numbers: marking given in the cited test reports

3 TEST RESULTS

An assessment of the performance of the product have been carried out by Notified Body 1390 and Accredited Testing Laboratory ATL No. 1007.1 - Centre of Building Construction Engineering, Joint Stock Company, workplace in Zlín, K Cihelně 304, 764 32 Zlín, ATL ITB Warszawa, ATL Pfb GmbH & Co and ATL ift Rosenheim. The test results are given in the Test Report No. 155 38035/2 issued ift Rosenheim NB No 0757 of 28.05.2009, in the Test Reports No. 102 38035/4; 102 38035/7 issued by ift Rosenheim (NB No. 0757) of 28.05.2009 (characteristic No. 1, 4, 9), in the Classification Report for reaction to fire NP-04205.4/09/BP issued by ITB Warszawa of 26.01.2010 (characteristic No. 2), in the Classification Report for resistance to external fire No. NP-04205.6/09/BP issued by ITB Warszawa of 26.01.2010 (characteristic No. 3), in the Test Report No. 173/09 issued by ATL No. 1007.1 of 10.03.2009 (characteristics No. 5, 6), in the Test Report No. 161 37555/Z20 issued by ift Rosenheim of 12.05.2009, in the Test Report No. 161 37555/Z21 issued by ift Rosenheim of 12.05.2009, in the Test Report No. 161 37555/Z22 issued by ift Rosenheim of 12.05.2009, in the Verification No. 175 38514/S71 issued by ift Rosenheim of 12.05.2009, in the Test Report No. 161 41544/Z72 issued by ift Rosenheim of 26.01.2010, in the test Report No. 161 41544/Z38 issued by ift Rosenheim of 08.04.2010, in the Test Report No. 10-001169-PB08-A01-04-de-01 issued by ift Rosenheim of 05.04.2011, in the Test Report No. 10-001169-PB11-A01-04-de-01 issued by ift Rosenheim of 05.04.2011, in the Test Report No. 10-001169-PB12-A01-04-de-01 issued by ift Rosenheim of 05.04.2011 (characteristic No. 7), in the Test Report No. 216/10 issued by ATL 1007.1 of 14.04.2010, in the Expert statement No. 09/06-A176-G1 issued by Pfb GmbH & Co, Stephanskircher of 03.08.2010, in the Expert statement No. 09/06-A176-G3 issued by Pfb GmbH & Co, Stephanskircher of 03.08.2010, in the Expert statement No. 12/08-A176-G2.2 issued by Pfb GmbH & Co, Stephanskircher of 14.10.2010, in the Expert statement No. 12/08-A250-G1 issued by Pfb GmbH & Co, Stephanskircher of 14.08.2012, in the Expert statement No. 12/08-A272-G1 issued by Pfb GmbH & Co, Stephanskircher of 30.08.2012, in the Expert statement No. 12/11-A361-G1 issued by Pfb GmbH & Co, Stephanskircher of 06.12.2012, Expert statement No. 14/11-A393-G1 issued by Pfb GmbH & Co, Stephanskircher of 27.01.2015 (characteristic No. 8). Test results whose were elaborated for roof windows WDF 84. H were used because construction of windows WDF R8. H is not different from this type in such a way that cannot affect test results. The summary of results is given in the following table 1.

Table 1 – The summary of results of an assessment of the performance of the product

Characteristic		Testing or calculation standard	Classification standard	Measured values at specimen	
1	Resistance to wind load	EN 12211	EN 12210	Class C3/B3	
2	Reaction to fire	EN 13823	EN 13501-1+A1	C	
3	External fire performance	ENV 1187	EN 13501-5+A1	B _{roof, t1}	
4	Watertightness	EN 1027	EN 12208	Class E1200	
5	Impact resistance (external impact)	EN 13049	EN 13049	Class 5 – 950 mm	
6	Load-bearing capacity of safety devices	EN 14609	EN 14351-1+A1 art. 4.8	Pass	
7	Acoustic performance (according type of glazing)*	EN ISO 10140-2 and EN ISO 717-1	Declared values	WD 2, 2T	40 (-3;-7) dB
				WD 3, 3T	34 (-1;-3) dB
				WD 4,5,4T,5T	34 (-2;-5) dB
				WD 6E	42 (-1;-5) dB
				WD 6S	42 (-2;-6) dB
				WD 8, 8A, 8G	39 (-2;-5) dB
				WD 9E	33 (-1;-4) dB
				WD 9A, 9G, 9P	37 (-2;-6) dB
8	Thermal transmittance	EN ISO 12567-2	Declared values	WD 3	1.3 W/(m ² .K)

	(according type of glazing)*			WD 2, 3T 4,5, 6S, 8, 8A, 8G	1.2 W/(m ² .K)
				WD 2T, 4T, 5T	1.1 W/(m ² .K)
				WD 6E	1.0 W/(m ² .K)
				WD 9A,9E	0.86 W/(m ² .K)
				WD 9G	1.0 W/(m ² .K)
				WD 9P	0.82 W/(m ² .K)
9	Air permeability	EN 1026	EN 12207	Class 3	

4 CONCLUSION

NB 1390 verifies conformity of the declared characteristics of the evaluated product with the results of tests of the product according to the used articles and Annex ZA EN 14351-1:2006+A1:2010.

5 VALIDITY OF REPORT ABOUT AN ASSESSMENT OF THE PERFORMANCE OF THE PRODUCT

Report about an assessment of the performance of the product is issued for definite specific constructional alternatives of the product arising during the production and assembly, provided the production processes and other productive technical documentations were complied with and under assumption that the quality of the production will be constant. This report is valid for the product made according to the given documentation. The report has unlimited time validity, more precisely, the report applies only to the time when a change occurs in some of the evaluated characteristics given by a change in documentation drawing for product construction, if there is a change of some of the used components in accordance with catalogues of suppliers, if the existing technical documentation validity is terminated, if there is a change of technologic process or material structure and up to the moment of the change of lawful requirements for product evaluation, or up to the moment when a further report updating the survey of the produced alternatives in accordance with newly expressed numerical values of relevant technical parameters and physical quantities is issued. This report shall not be reproduced except in full, without written approval of the NB 1390.

6 BASES UTILIZED FOR REPORT PREPARATION

1. Application for the execution of the Notified Body activity No. 0060/10/Z;
2. Application for revision of ITT Report of 12.06.2015;
3. Application for revision of ITT Report of 10.12.2015;
4. Technical description of supplied specimens;
5. Drawings;
6. Installation instructions;
7. Test Report No. 173/09 issued by ATL No. 1007.1 of 10.03.2009;
8. Test Report No. 155 3805/2 issued by ift Rosenheim NB No. 0757 of 28.05.2009
9. Test Report No. 102 38035/4; 102 38035/7 issued by ift Rosenheim (NB No. 0757) of 28.05.2009;
10. Classification Report for reaction to fire No. NP-04205.4/09/BP issued by ITB Warszawa of 26.01.2010;
11. Classification Report for resistance to external fire No. NP-04205.6/09/BP issued by ITB Warszawa of 26.01.2010;
12. Test Report No. 161 37555/Z20 issued by ift Rosenheim of 12.05.2009;
13. Test Report No. 161 37555/Z21 issued by ift Rosenheim of 12.05.2009;
14. Test Report No. 161 37555/Z22 issued by ift Rosenheim of 12.05.2009;
15. Verification No. 175 38514/S71 issued by ift Rosenheim of 12.05.2009;
16. Test Report No. 161 41544/Z72 issued by ift Rosenheim of 26.01.2010;

17. Test Report No. 161 41544/Z38 issued by ift Rosenheim of 08.04.2010;
18. Test Report No. 216/10 issued by ATL 1007.1 of 14.04.2010;
19. Expert statement No. 09/06-A176-G1 issued by Pfb GmbH & Co, Stephanskircher of 03.08.2010;
20. Expert statement No. 09/06-A176-G3 issued by Pfb GmbH & Co, Stephanskircher of 03.08.2010;
21. Expert statement No. 12/08-A176-G2.2 issued by Pfb GmbH & Co, Stephanskircher of 14.10.2010;
22. Test Report No. 10-001169-PB08-A01-04-de-01 issued by ift Rosenheim of 05.04.2011;
23. Test Report No. 10-001169-PB11-A01-04-de-01 issued by ift Rosenheim of 05.04.2011;
24. Test Report No. 10-001169-PB12-A01-04-de-01 issued by ift Rosenheim of 05.04.2011;
25. Expert statement No. 12/08-A250-G1 issued by Pfb GmbH & Co, Stephanskircher of 14.08.2012;
26. Expert statement No. 12/08-A272-G1 issued by Pfb GmbH & Co, Stephanskircher of 30.08.2012;
27. Expert statement No. 12/11-A361-G1 issued by Pfb GmbH & Co, Stephanskircher of 06.12.2012;
28. Expert statement No. 14/11-A393-G1 issued by Pfb GmbH & Co, Stephanskircher of 27.01.2015.